

CHECK VALVES

CHK SERIES

INTRODUCTION

One-way valve for in-line use.

Suitable for any type of hydraulic system using liquids that are not highly viscous.

The standard types are in trivalent plated carbon steel and are therefore especially suitable for non-corrosive mineral based oils and liquids.

APPLICATIONS

Construction, mobile hydraulics, test equipment, machine tools, agricultural and general hydraulics.

MATERIALS

Valve body in trivalent plated carbon steel.

Piston in carbon steel.

Internal spring in silicon steel (stabilized).

TECHNICAL DETAILS

One-way valve.

Operating temperatures: -40°C to 150°C

Standard cracking pressures:

- 1/4" to 1" sizes: 0.35 bar
- 1-1/4" to 2" sizes: 0.5 bar (other cracking pressures, on request)



ALTERNATIVE USES

Can be used as a pressure sequence valve by adjusting the internal spring to an appropriate cracking pressure. For flow restrictor check valves a central bleed hole can be provided, on request, sized to customer requirements.

Performance Characteristics	Valve Size							
	1/4"	3/8"	1/2"	3/4"	1"	1-1/4"	1-1/2"	2"
Maximum	400 Bar	400 Bar	350 Bar	350 Bar	350 Bar	250 Bar	250 Bar	250 Bar
Working Pressure	5800 PSI	5800 PSI	5075 PSI	5075 PSI	5075 PSI	3625 PSI	3625 PSI	3625 PSI
Standard	0.35 Bar	0.35 Bar	0.35 Bar	0.35 Bar	0.35 Bar	0.5 Bar	0.5 Bar	0.5 Bar
Cracking Pressure	5.1 PSI	5.1 PSI	5.1 PSI	5.1 PSI	5.1 PSI	7.3 PSI	7.3 PSI	7.3 PSI
Burst Pressure	1200 Bar	1200 Bar	1050 Bar	1050 Bar	1050 Bar	750 Bar	750 Bar	750 Bar
	17400 PSI	17400 PSI	15225 PSI	15225 PSI	15225 PSI	10875 PSI	10875 PSI	10875 PSI
Rated Flow	12 L/min	23 L/min	45 L/min	100 L/min	189 L/min	250 L/min	379 L/min	757 L/min
	3.2 GPM	6.1 GPM	12 GPM	26.4 GPM	50 GPM	66 GPM	100 GPM	200 GPM



Dimensions

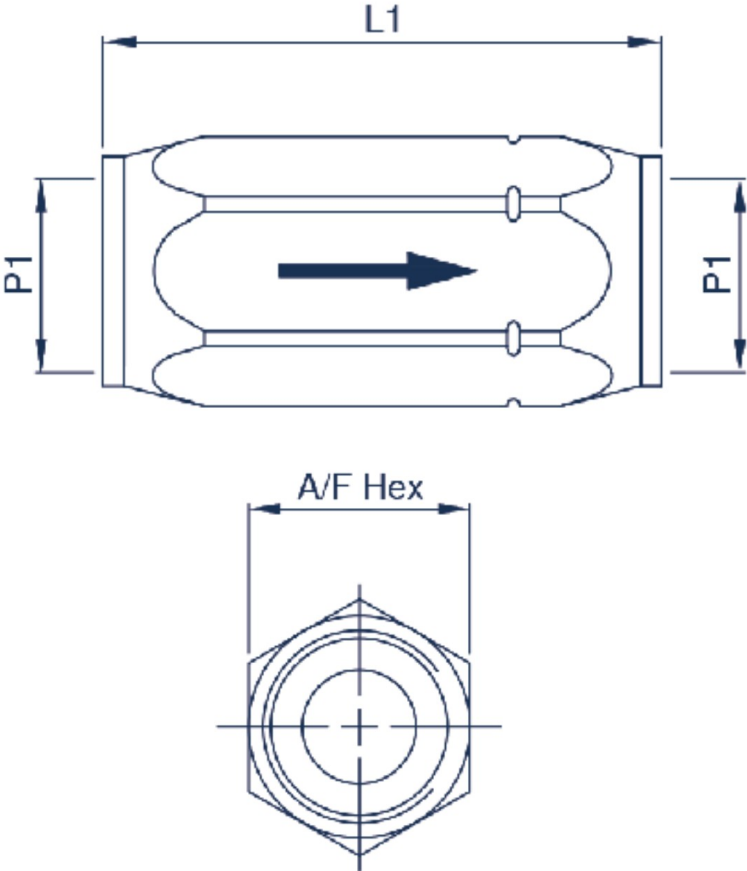

Part Number	Body Size	P1 (thread)*	L1	AF
CHK-BPF-04-0.35	1/4"	1/4 BSPP F	58	19
CHK-BPF-06-0.35	3/8"	3/8 BSPP F	62.2	24
CHK-BPF-08-0.35	1/2"	1/2 BSPP F	79.2	30
CHK-BPF-12-0.35	3/4"	3/4 BSPP F	83.1	36
CHK-BPF-16-0.35	1"	1-0 BSPP F	106.2	45
CHK-BPF-20-0.5	1-1/4"	1-1/4 BSPP F	127	55
CHK-BPF-24-0.5	1-1/2"	1-1/2 BSPP F	138	65
CHK-BPF-32-0.5	2"	2-0 BSPP F	160	75

* BSP threads are standard. Other thread forms available on request.

All dimensions in mm unless otherwise stated. Dimensions shown are for guidance only, if critical contact FCL staff.

✓ The right connector
 ✓ The right price

www.fluidconnectors.com

NZ: +64 9 274 4830
 AU: +61 8 9244 8266

